

ISUZU

**FOR ADDITIONAL
INFORMATION ON ISUZU'S
FULL LINE OF LOW CAB
FORWARD TRUCKS
PLEASE VISIT**

**WWW.ISUZUCV.COM
OR CALL (866) 441-9638**

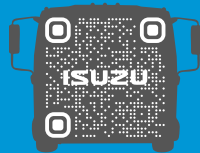

**SCAN TO ACCESS A DIGITAL COPY
OF THE 2025 NRR EV BROCHURE**

ISUZU

All photographs, illustrations, equipment, and technical data in this brochure are based on the latest information available at the time of publication. Isuzu Commercial Truck of America, Inc. reserves the right to make changes at any time, without notice, in prices, colors, materials, equipment, specifications, and models, and to discontinue models or equipment. Isuzu vehicles are assembled from component parts manufactured by Isuzu Motors Limited, its affiliated companies, and by independent suppliers who manufacture such components to Isuzu's exacting standards for quality, performance, and safety. Some vehicles are shown with optional equipment. Some equipment is dealer installed. Visit your authorized Isuzu dealer for warranty and other details. Android Auto is a trademark of Google LLC. Apple Carplay is a registered trademark of Apple Inc. Bluetooth is a registered trademark of Bluetooth SIG, Inc. SiriusXM is a trademark of Sirius XM Radio Inc. HD Radio is a registered trademark of iBiquity. Facebook is a registered trademark of Meta. Instagram is a registered trademark of Meta. X is a trademark of X Corp. YouTube is a registered trademark of Google Inc. Neither Isuzu Commercial Truck of America, Inc. nor Isuzu Motors Limited are sponsored by or affiliated with these platforms. FleetValue is a registered trademark of Isuzu Commercial Truck of America, Inc. Copyright © 2024 Isuzu Commercial Truck of America, Inc.



2025 ISUZU NRR EV

EVERYTHING YOU WANT FROM AN ELECTRIC TRUCK EVERYTHING YOU EXPECT FROM ISUZU

The name Isuzu has become synonymous with innovation in transportation. Now, Isuzu brings you its first battery electric truck: the 2025 NRR EV. The truck that puts the EV in "EVerything."

- 19,500-pound GVWR to handle your Class 5 demands
- Wheelbases ranging from 132.5 to 176 inches to accommodate bodies up to 20 feet
- Four battery capacity choices, the largest provides a cruising range of up to 235 miles*
- DC fast charging and AC (level 2) charging capability
- Electric Power Take-off (ePTO)
- New cab, engineered to increase safety and comfort
- Standard driver and outboard passenger SRS frontal airbags
- A standard Advanced Driver Assistance System (ADAS) package designed to improve driver, passenger and pedestrian safety helping reduce the number and severity of collisions
- Isuzu's enhanced keyless entry allows for EV system startup, door lock/unlock, and more
- Extended warranty protection and maintenance coverage for up to five years with registration in Isuzu Group Connect

And that's just the beginning. The all-new 2025 Isuzu NRR EV. It's EVerything you want from an electric truck—and EVerything you expect from Isuzu.



* All figures are calculated estimates and based on a fully charged battery. For comparison purposes only. Battery capacity decreases with time and use. Actual range will vary based on a number of factors, including number of battery packs, vehicle options, driving conditions and habits, vehicle and battery's condition, and outside temperature.

ELECTRIC POWER WITHOUT COMPROMISE

Isuzu has been the best-selling brand of low cab forward trucks every year since 1986 because our trucks are engineered to solve your transportation problems. Maintaining that tradition, the 2025 Isuzu NRR EV has been designed with you and your work in mind.

Power you can count on. Every NRR EV is powered by a number of 20 kilowatt-hour, lithium-ion battery packs.

A range of ranges. Why buy more battery capacity than you'll use—or settle for less than you need? Isuzu offers four battery configurations so you can choose the combination that's right for your needs.

Real-world capability. The battery packs provide power to a three-phase, 150-kilowatt electric drive motor that delivers 280 lb-ft of torque, the kind of performance you'd expect from a Class 5 truck.

Electric Power Take-off (ePTO). The NRR EV's ePTO technology—similar to what is available on an internal combustion engine (ICE) truck—"takes power off" the vehicle's power source to drive auxiliary equipment and systems. Because the NRR EV's power source is electric, that means no fossil fuels for your power take-off needs. This is especially important for companies wishing to promote sustainability and reduce their carbon footprint.

Battery Packs	Battery Capacity (kWh)	Wheelbase (in.)	Cab to Axle (in.)	BOC (in.)	Frame Height (in.)	Curb Weights (lbs.)	Payloads (lbs.)	GVWR (lbs.)	Range (mi.)*
3	60	132.5	110	7.7	33.5	6549	12951	19,500	41-80
		150	127.5			6602	12898		
		176	153.5			6699	12801		
5	100	132.5	110			7563	11937		68-130
		150	127.5			7616	11884		
		176	153.5			7716	11784		
7	140	176	153.5			8684	10816		95-180
9	180	176	153.5			9618	9882		122-235

*All figures are calculated estimates and based on a fully charged battery. For comparison purposes only. Battery capacity decreases with time and use. Actual range will vary based on a number of factors, including number of battery packs, vehicle options, driving conditions and habits, vehicle and battery's condition and outside temperature.

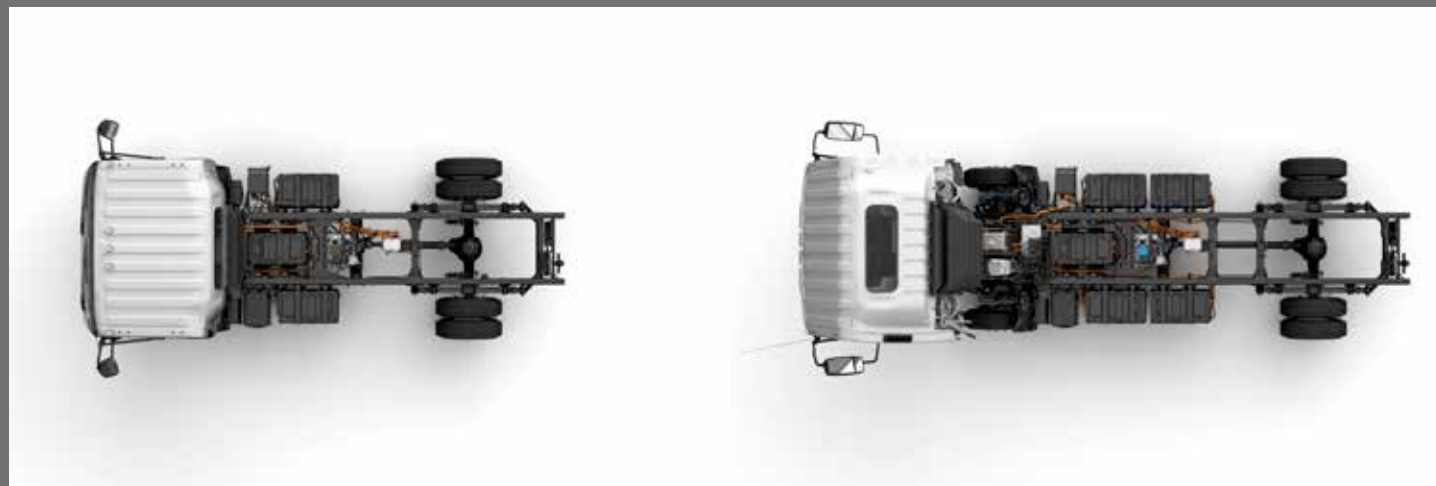
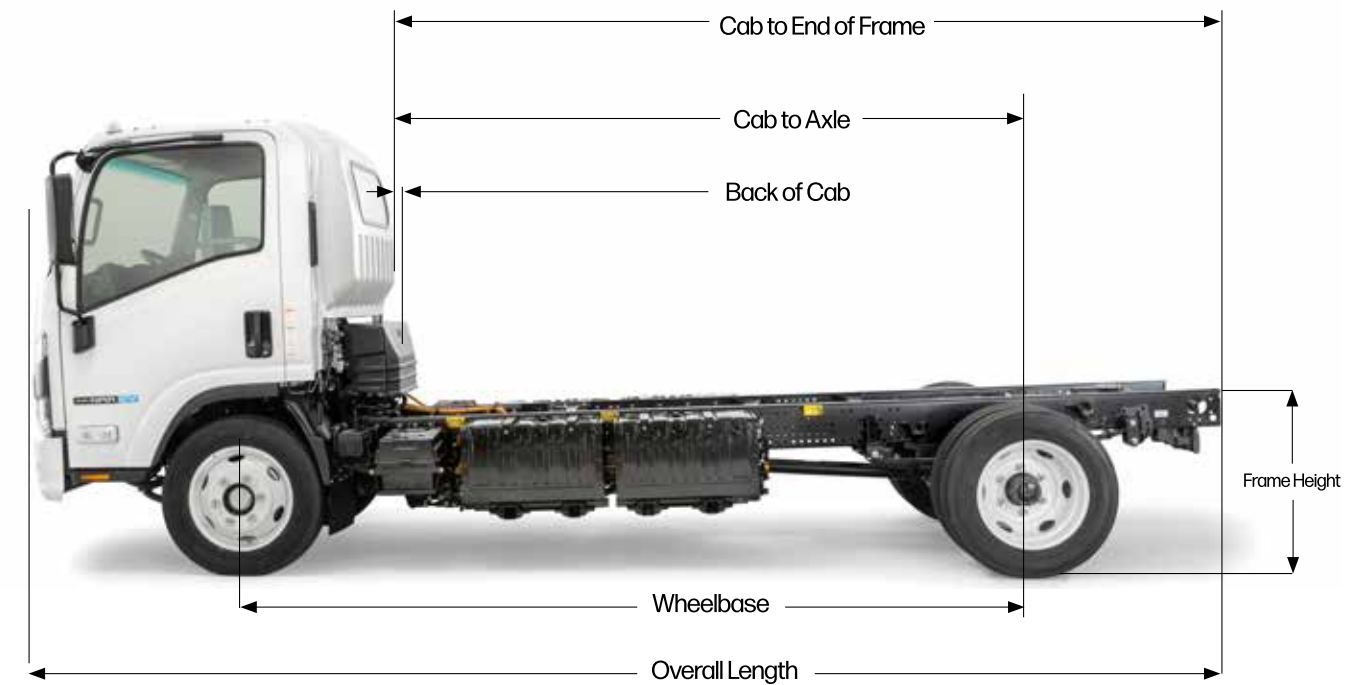

3 Battery Packs - 60 kWh

5 Battery Packs - 100 kWh



7 Battery Packs - 140 kWh

9 Battery Packs - 180 kWh

CHARGING FORWARD

For ease of charging, the NRR EV is equipped with charging ports that accommodate the most popular charging connectors in the U.S.:

- Level 2 AC charging (J1772)
- Level 3 DC “fast” charging (CCS1)

Charging time varies depending on charging output and the condition of the batteries. Isuzu recommends operating the NRR EV with the batteries charged to 90% of their capacity, and recharging when the batteries are above 20% of their capacity. The chart to the right shows the charging time from 20% to 90% for each battery configuration.

Running hot and cold. Isuzu trucks are sold in over 150 countries around the world and are expected to operate in every conceivable type of climate. An electric truck from Isuzu must meet that same expectation. As a result, Isuzu engineers developed a battery temperature management system to ensure operation in both extreme heat and the punishing cold.

CHARGING TIMES

	60 kWh	100 kWh	140 kWh	180 kWh
Normal charge (AC)	7.2 kW 6.5 hours	19.2 kW 4 hours	19.2 kW 5.7 hours	19.2 kW 7.3 hours
Rapid charge (DC)	42 kW 12 hours	70 kW 12 hours	80 kW 1.5 hours	80 kW 1.8 hours

All times are approximate. DC charging time will be longer in cold regions. Please allow up to one hour additional charging time in cold regions.

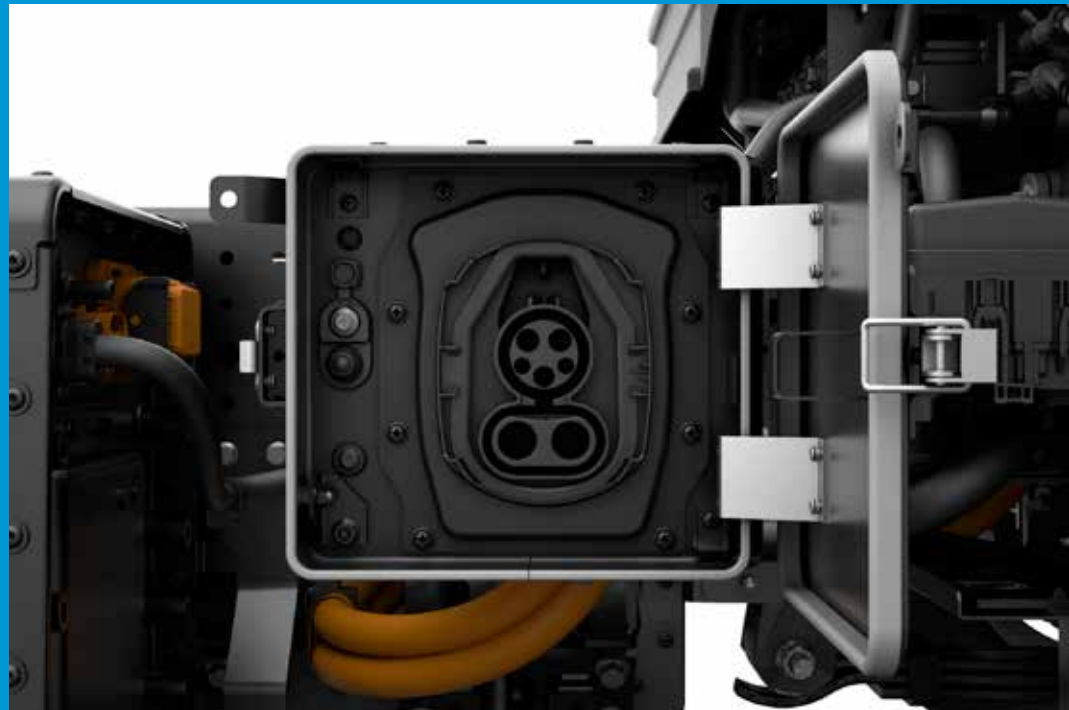

The NRR EV’s high voltage batteries and electric drive motor are cooled by a water-based coolant. Without sufficient cooling, drive motor output will decrease; high-voltage battery output will drop; charging time will increase.

The battery temperature management system also responds to freezing weather—even when the truck is turned off. Heating control is activated to prevent the battery’s temperature from reaching a level (approximately -4° Fahrenheit) that makes it impossible to start the truck. The batteries’ state of charge must be above 0% for the system to operate.

CHARGE LESS CRUISE LONGER

“Range anxiety” is one of the most common concerns of electric vehicle drivers. Is the manufacturer’s stated range accurate? Will I run out of power before I reach a charging station? Will I be left stranded?

Understanding factors that reduce cruising distance is the first step toward eliminating range anxiety:

- Operating in extremely cold or hot regions
- Using electricity (for example, operating a liftgate)
- Carrying a heavy load
- Driving at high speeds
- Driving mostly on slopes
- Infrequent and/or low-power use of regenerative braking

Careful, EV-appropriate driving behavior will address most of these issues, and the NRR EV has multiple technologies designed to optimize energy consumption.

Regenerative braking. With a conventional hydraulic braking system using disc or drum brakes, friction braking takes the kinetic energy moving your vehicle forward and turns it into heat rather than motion. Although it’s effective at slowing a moving vehicle, friction braking wastes energy. The regenerative braking system captures kinetic energy and transfers it into the vehicle’s batteries. The system wastes less energy than friction braking does. Using regenerative braking helps preserve and replenish range in an electric vehicle.

The Isuzu regenerative braking system offers three levels of energy regeneration. We recommend using the setting with the highest regenerative power to maximize driving range.

ECO Mode. Activated by the switch on the base of the shift lever, ECO Mode reduces acceleration performance and battery consumption. When ECO Mode is on, the mode indicator in the instrument panel will illuminate.

Heated seat. Unnecessary heating can have an adverse effect on driving range. To suppress excessive heating, we recommend using the standard heated driver seat instead of the heater.



Heated Driver Seat

Eco Mode



THE SUPERIOR EXTERIOR

The 2025 NRR EV features a new cab that's just as innovative as its power source. This is not styling just for the sake of styling—this is a cab that has been engineered to be safer and more efficient than ever.

“World Cross Flow”. This is the new global Isuzu brand design language and it speaks volumes on the NRR EV. Designers created a look that would cheat the wind while maintaining an unmistakable Isuzu identity.

- As the quietest and most efficient Isuzu cab ever, the enhanced aerodynamics allow better air flow around the cab and keep the sound to a whisper.
- The striking new grille continues the “smile” theme of previous generations while maintaining its bold exterior styling.
- The new front bumper design improves cooling performance and reduces repair costs.
- The refined corner panels create aerodynamic efficiency without compromising a wide 85-degree door opening.

The LCF Advantages. Like every Isuzu truck, the NRR EV serves up all the benefits of a low cab forward design. Compared to conventional cabs, that means:

- Up to 16 feet more ground view for increased forward visibility
- Bodies up to four feet longer with equivalent wheelbases to accommodate more cargo
- Tighter turning radius for superior maneuverability

The sound of innovation. Because electric vehicles do not create engine noise, speakers at the front and rear of the NRR EV that generate proximity warning sounds have been installed to alert nearby pedestrians that the truck is operating. This system is activated when vehicle speed is 12.4 MPH or less, or when the truck is backing up.

Don't be afraid of the dark. The all-new headlamp assembly employs LED clearance lights, turn signals, high and low beams, and daytime running lights. This lamp design lights a larger area to provide better visibility of the road ahead. And if mud, snow, ice, or other debris should cover the headlamp, the driver can conveniently activate the new pop-up headlamp washers.

To add to the convenience and safety, when the headlamps are set in the “Auto” position, you won't have to worry about forgetting to turn the lamps on—or off—again. An ambient light sensor detects light levels outside the truck. When it detects a lower light level, the headlamps will automatically illuminate—along with the various vehicle running lights.

An innovative and stronger frame. When we say the NRR EV is new, we mean it. The frame is crafted of HT540 hot-rolled steel. This high-tensile-strength steel provides a taller frame rail and a more rigid frame. The result? A frame with increased strength. And strength has always been one of Isuzu's . . . strengths.

In short, the NRR EV's new cab isn't simply better looking. It's simply better.



AHEAD OF THE CURVE BEHIND THE WHEEL

If greater driver comfort equals improved driver productivity, and improved productivity equals higher profits, then the 2025 NRR EV can bring your business to new levels of success. Here are just a few of the ways the interior has been thoughtfully redesigned with driver comfort, convenience, productivity and safety in mind.

Start with the steering wheel. The steering wheel's position and angle have been changed from prior Isuzu cabs to provide a better fit for a wider variety of drivers. Its smaller diameter means easier handling. And now, steering-wheel mounted controls operate the Multi-Information



Display, audio system, cruise control, hands-free phone calling and more.

Putting the "multi" in Multi-Information Display (MID). A new seven-inch color MID is standard equipment, and it houses a remarkable assortment of gauges and functions, including warning lights; status of driver-assistance features; time and temperature; odometer; shift position and so much more. For example, this MID is designed to minimize eye movements so that it maximizes driver comfort and safety. And it's not just multi-information—it's multi-lingual, fluent in English, French and Spanish.

A new pedal meets the metal. The pedal layout has been engineered to reduce fatigue when switching between the accelerator and brake pedal.

INTERIOR MOTIVES

Climate change that you'll appreciate. Climate controls adopt a new electronic control that makes operation easy and intuitive. And when the climate on the outside turns wet, drivers will appreciate the new variable intermittent windshield wipers.

Please be seated. The NRR EV offers three-across seating, and all three adults will be comfortable, thanks to new urethane seat cushions and upholstery. In addition, the driver's seat back is 30 millimeters higher than prior N-Series seats to accommodate taller drivers, while the driver and outboard passenger's hip points have been lowered 10 millimeters for a better seating position. And to increase comfort and reduce fatigue, the driver's seat now features an armrest.

Smartest key in the room. The NRR EV is equipped with Isuzu's new enhanced keyless entry. Just how smart is it? It will allow you to lock and unlock the doors and start the vehicle without removing the remote control unit from your pocket, alert the driver if the key is left in the cab, and sound the horn and flash the turn signals if necessary to locate the truck.

Stay hydrated. It's easy, because the NRR EV features a total of four cupholders that will easily accommodate 500ml-size water bottles.

Other interior enhancements:

- Brighter LED interior lighting that lasts longer
- New overhead console design expands storage
- New card holder clip for additional functionality
- Expanded passenger tray capacity with enough room to store the owner's manual

Put all of these features together and it's clear that the NRR EV cabin is a place that makes work . . . a pleasure.



SAFETY FIRST

The 2025 NRR EV comes with the most complete range of safety features Isuzu has ever offered, including four-wheel anti-lock brakes, hydraulic brake assist, electronic brake-force distribution, anti-slip regulation and electronic stability control—plus these new features:

Standard driver and outboard passenger SRS frontal airbags. Driver and outboard passenger SRS frontal airbags are standard on every 2025 Isuzu NRR EV.

Remember, airbags are supplemental protection and are designed to work in combination with seatbelts.

Standard Automatic Brake Hold (ABH). While waiting at a traffic light or when stopped on a slope, the truck will remain temporarily stopped even if the driver takes their foot off the brake pedal. This can prevent slipping backwards down slopes and rear-end collisions caused by creep. ABH also improves driver comfort by reducing pedal fatigue.

In addition, every NRR EV is equipped with a robust suite of driver-assistance features at no extra charge. The chart on the opposite page has the details.



STANDARD ADVANCED DRIVER ASSISTANCE SYSTEM (ADAS)

LANE DEPARTURE WARNING SYSTEM (LDWS)

- Operates at speeds of approximately 37 miles per hour and above
- Recognizes the lines on road ahead to determine if vehicle strays too far from road's center
- Visual and audible alerts on MID
- Two sensitivity levels

AUTOMATIC EMERGENCY BRAKING SYSTEM (AEBS)

- Monitors road ahead for obstacles such as pedestrians, cyclists, other vehicles
- Warns the driver of such obstacles with visual and audible alerts on MID
- If necessary, will automatically apply braking force to reduce vehicle speed
- Operates at speeds of approximately 6 miles per hour or higher

FOLLOWING DISTANCE WARNING

- Notifies driver when front of Isuzu truck is within a certain distance of vehicle ahead
- Distance is adjustable by driver
- Visual and audible alerts on MID

FORWARD VEHICLE START NOTIFICATION

- From a stop, notifies driver when the vehicle in front of the Isuzu truck has moved forward a certain distance (at a traffic light or stop sign, for example)
- Visual and audible alerts on MID

MIS-ACCELERATION MITIGATION

- When starting from a stop and, an obstacle in front of the Isuzu truck is detected, engine output will be restricted if the accelerator is depressed more than necessary
- Helps prevent or lessen the severity of accidents caused by mistaken accelerator pedal depression
- Operates when Isuzu truck is parked or operating at 6 miles per hour or slower

FULL-RANGE ADAPTIVE CRUISE CONTROL

- Allows driver to set both a desired speed and a desired following distance from the vehicle ahead
- If the vehicle ahead slows down, the system will automatically slow the Isuzu truck to maintain pre-set following distance
- System will then accelerate the Isuzu truck to the originally set speed once vehicle ahead speeds up or the lane is clear
- System can bring the Isuzu truck to a complete stop. If it does, the Isuzu truck will return to its originally set speed only after the driver depresses the accelerator



GET CONNECTED

Gasoline- and diesel-powered vehicles allow owners and operators to detect signs of failure from operating sounds and smells. Not so with electric vehicles. But thanks to our exclusive Isuzu Group Connect suite of telematics services, it's possible to understand the NRR EV's vehicle status and manage charging plans remotely—on your personal computer.

Isuzu Group Connect allows you to monitor—from a distance—the status of every NRR EV in your fleet, including:

- Cruising distance
- Battery level (state of charge)
- Charging status
- Charging history

Isuzu Group Connect also allows you to create a charging plan based on each vehicle's usage and any power usage limit that you have set.

And Isuzu Group Connect will even display the most recently scheduled maintenance parts, based on mileage and maintenance history, and the next scheduled maintenance date or distance.

Connect is available at no extra charge on every 2025 NRR EV—and it includes all the advantages of Isuzu's outstanding extended electric vehicle warranty coverage.

Isuzu Group Connect is your connection to peace of mind.

TRUSTWORTHY QUALITY PROGRAMS



Call (866) 441-9659 – 24/7/365 – It is as simple as that when you're in need. Roadside Assistance is standard on all new Isuzu trucks. Please see your authorized Isuzu dealer for details.



Isuzu Genuine Parts are specifically designed replacement parts for Isuzu trucks, are approved for all warranty repairs, and carry a one-year unlimited mile warranty. See your Isuzu dealer for warranty details.



Isuzu FleetValue Parts are priced to compete with aftermarket parts—but have been engineered to meet Isuzu's stringent specifications and exacting standards for quality, performance, safety and reliability. And they carry a one-year, unlimited-mile warranty.



Isuzu Finance of America offers exclusive programs, through authorized Isuzu dealers nationwide, that allow qualifying customers to take advantage of low monthly payments. Ask your Isuzu dealer for more information on Isuzu Finance offerings that will best fit your business needs!